

# Technical Instruction

# 0237EN

ContiTech part no.	Applications	Engine codes
<b>CT1092WP1</b>	<b>Citroen</b> Berlingo (B9,MF), C2, C3, C4, C5, Jumpy, Xsara Picasso <b>Fiat</b> Scudo <b>Ford</b> Fiesta V-VI, C-Max, Focus II, Fusion <b>Mazda</b> 3 (BK) <b>Mini</b> (R56) One D, Cooper D <b>Peugeot</b> 206, 207, 3008, 307, 308, 407, 1007, 5008 Expert, Partner <b>Suzuki</b> SX4 DDIS <b>Volvo</b> C30, V40, V50, V70  <b>Various 1.6 HDI/TDCI from 2004</b>	9HZ, 9HY(DV6TED4), 9HN(DV6ETED4), 9HT(DV6BTED4), 9HX(DV6ATED4), 9HW(DV6ETED), 9HP(DV6DTED), 9HU(DV6UTED4), G8DA, G8DB, G8DC, G8DD, GPDA, GPDC, G8DE, G8DF, HHDA, HHDB, HHJA, HHJB, HHJC, HHJD, HHJE, HHJF, UBJA, N47C16 A

## Contents

ContiTech #	Type	Quantity
CT1092	Timing belt	1x
V55953	Tensioning pulley	1x
V55954	Idler	1x
WP6014	Water pump	1x

Only to be fitted by a trained professional.  
The carmaker's fitting instructions must be complied with.

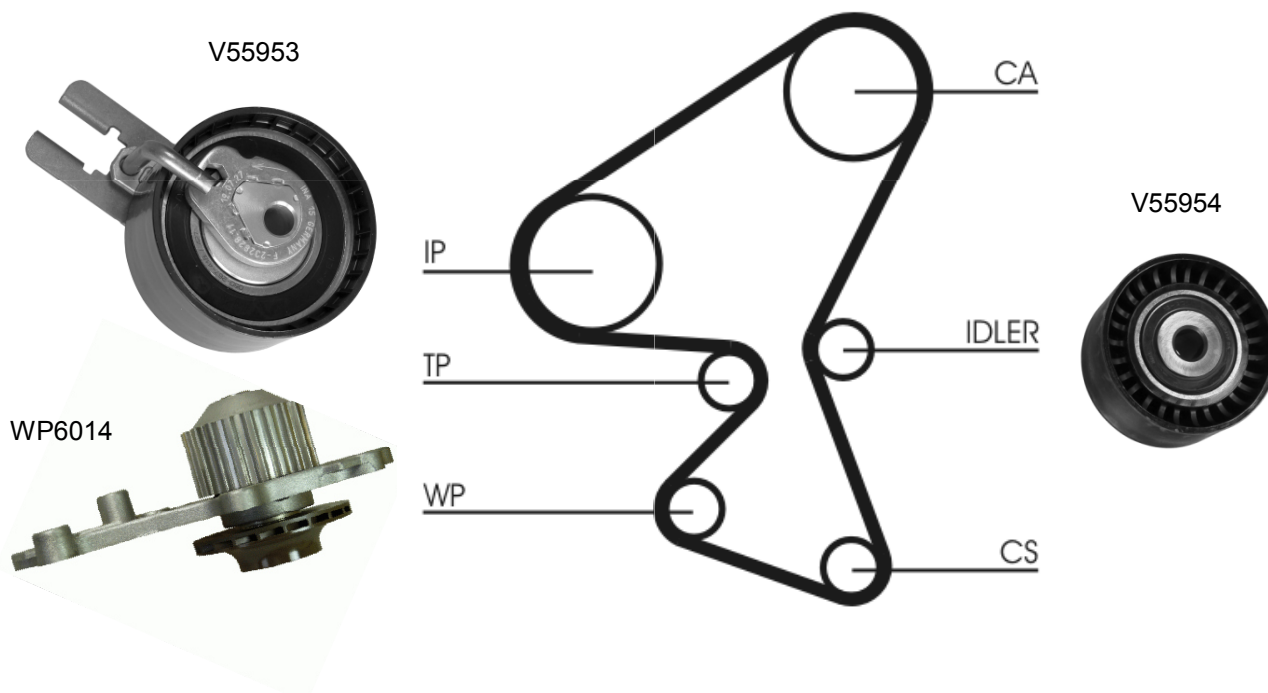
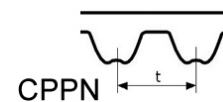

# Technical Instruction

# 0237EN

## Removal

### Special tool(s)

Tool #	Type	Function
CA pin	Ford 303-735	To lock camshaft
Locking pin	Ford 303-732	To lock injection pump sprocket/crankshaft sprocket
CS pin	Ford 303-734	To counterhold crankshaft bolt
Coolant hose clip	Ford 303-397	To detach coolant reservoir

- Remove ancillary drive belt, drain coolant at expansion reservoir hose, cover alternator in advance.
- Support engine securely using jack and pad.
- After unscrewing 4 nuts, remove front engine mount (nuts must be changed: 80 Nm top and 90 Nm bottom).
- Remove upper guard, then unscrew 4 horizontal bolts of engine mount flange, loosen CS vibration damper using impact wrench (Mini: actuated holding interlock) and remove, then finally remove lower guard.
- Turn engine in direction of engine rotation until bore in CA pulley aligns with cylinder head bore (approx. 10-o'clock position) **[A]**.
- Loosen tensioning pulley, remove timing belt.
- Remove crankshaft sprocket after detaching lower guide **[B]**.

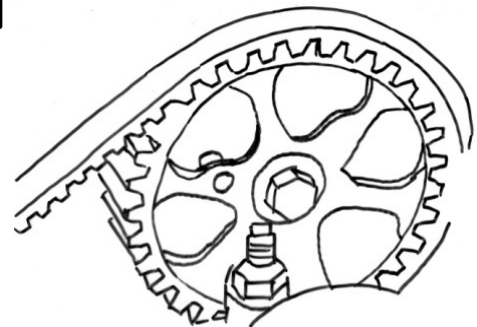
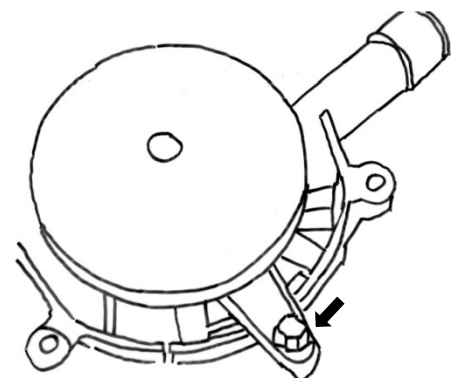
**A**

**B**

# Technical Instruction

# 0237EN

## Fitting

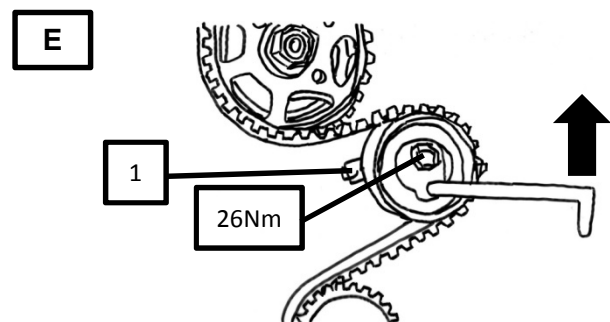
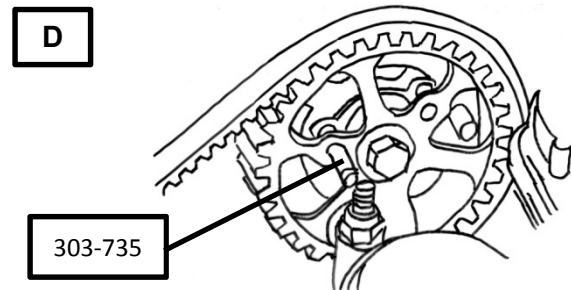
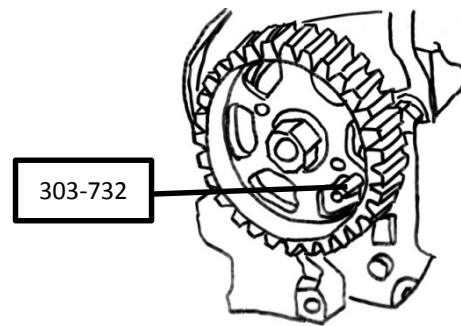
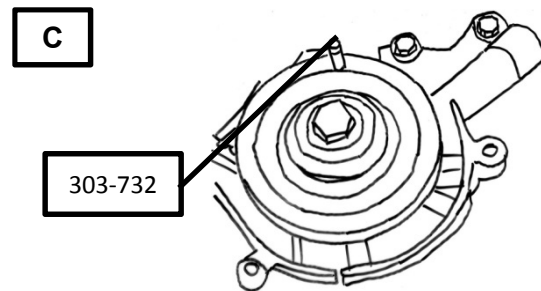
- Check that crankshaft key is correctly seated. Do not touch sensor ring. Hand-tighten CS sprocket again using central bolt.
- Insert pins 303-732 [C] and 303-735 [D] in all 3 pulleys as a check and then remove again.
- Change tensioning pulley, idler (37 Nm) and water pump (10 Nm), fit timing belt in direction of engine rotation.
- Tension timing belt using hex key. To do so, turn eccentric counterclockwise [E] until marks (1) align, then tighten bolt to 26 +/- 3Nm.
- Remove pin 303-732 and screw lower guide plate back in place, tightening to 10 Nm [B].
- Turn crankshaft 10x, insert pins 303-732 and 303-735 into sprockets again as a check, and then remove once more.
- Unscrew CS bolt, insert crankshaft pin 303-734 into block at rear, then turn engine further as far as stop.
- Fit engine mount flange (55 Nm) and guard (7 Nm).
- Tightening torque for **new** crankshaft bolt is 30 Nm + 180°.



ContiTech assumes no liability in connection with this publication.  
It may not be duplicated or published without ContiTech's consent.